

Applications for:

Fast Vessels WVS/WLS

Engine Rating up to 1,400 kW

Fast Vessels WVS/WLS

Engine Rating up to 5,000 kW

Fast Ferries VLJ

Engine Rating up to 13,200 kW

Work Boats WAF/LAF

Engine Rating up to 1,200 kW

Work Boats WAF/LAF

Engine Rating up to 3,650 kW

Work Boats 1,400 - 30,000 kW

DLG 1113-110131

Work Boats WAF/LAF

Engine Rating up to 8,500 kW

Work Boats VA

Engine Rating up to 6,000 kW

Work Boats SVA¹⁾/SVAL²⁾

Engine Rating up to ¹⁾ 20,000 kW

Engine Rating up to ²⁾ 13,000 kW

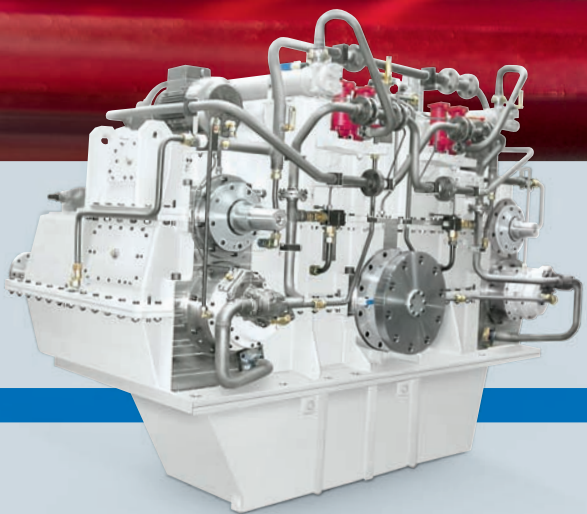

Y O U R P A R T N E R F O R T H E F U T U R E



REINTJES

Applications for Work Boats

DLG 1113 - 110131

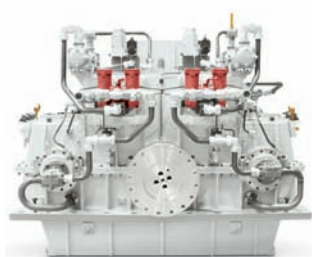

Twin input/single output reduction gearbox, horizontally offset

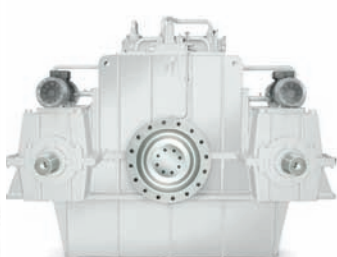

Twin input/single output reduction gearbox U-Drive design, horizontally offset

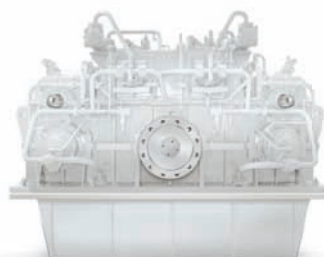

Twin input/single output reduction gearbox with PTO, horizontally offset

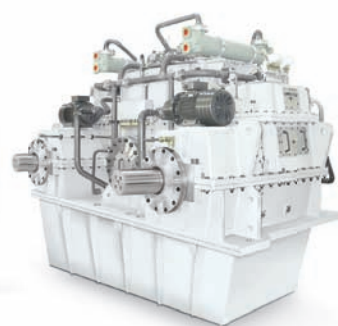

Twin input/single output reduction gearbox with PTO, horizontally offset

Advantages

Gearboxes of the DLG series have been specially designed for work boats such as tugs, container-vessels, ferries and special-purpose ships with similarly high performance demands. We have the backing of over 75 years of experience in marine gearbox production and use

state-of-the-art computation tools and production technologies.

Owing to their design for specific areas of application, the hydraulically operated twin in/single-out reduction gearboxes of the DLG series offer various special advantages:

- High operating reliability
- Simple operation and maintenance
- Compact dimensions
- Low operating noise

Gearbox Selection

The diagram opposite gives an overview of the performance ratings of the basic DLG types.

However, for the final selection of gearboxes please contact REINTJES.

DESIGNED FOR HEAVY DUTY APPLICATIONS



Engine Power

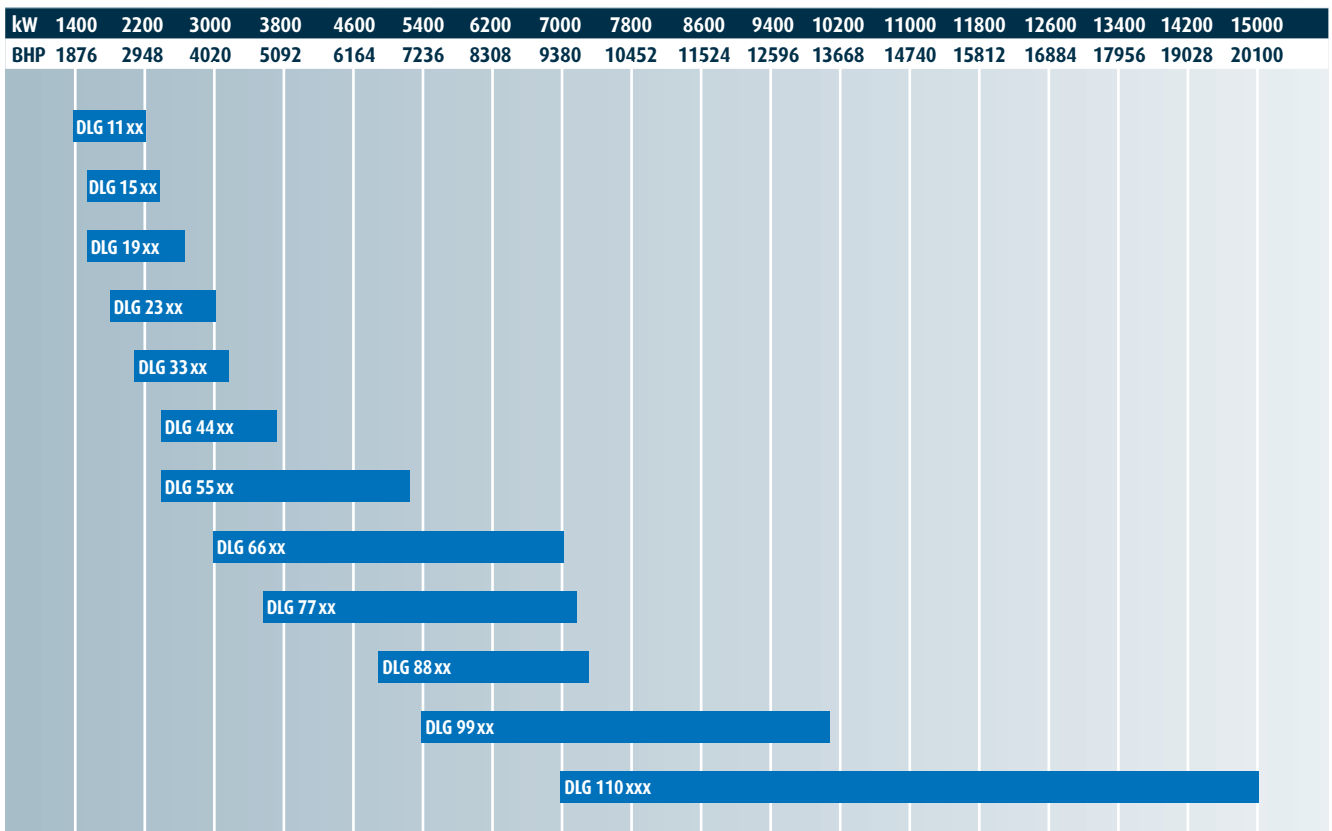

* Gearbox designation e.g. DLG 19xx: 19 => size of clutch, xx => variations of output shaft-sizes (13,16,31, ... 131)

Marine gearboxes

DLG 1113-110131

DLG 1113 - 3331

Twin input/single output reduction gearbox with hydraulically operated clutches
Horizontally offset

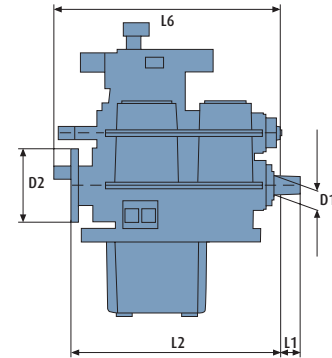
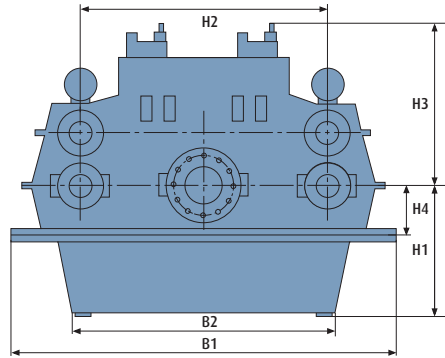

Gearbox DLG	Main Dimensions (mm)											Weight kg ¹⁾
	B1	B2	D1	D2	H1	H2	H3	H4	L1	L2	L6	
1113	3050	2040	107	620	1000	2000	1255	350	142	1240	1430	9500
1116	3000	1900	107	560	1000	2000	1350	350	142	1450	1640	12000
1513	3050	2040	117	510	1000	2000	1250	350	154	1510	1730	9500
1516	3330	2400	117	600	750	2250	1800	400	154	1398	1650	13500
1913	2780	2100	127	550	1000	2000	1650	400	162	1440	1750	10500
1916	3400	2880	127	600	1150	2500	1800	360	162	1450	1750	15000
1925	3500	2700	127	670	1310	2500	1800	460	162	1440	1750	16000
1931	3900	2700	127	710	1210	2300	1640	540	162	1735	2000	22500
2316	2800	2000	162	600	1030	2300	1580	390	198	1620	2000	19000
3325	3060	2250	167	770	1250	2500	1500	440	198	1715	1920	19000
3331	3060	2080	167	915	1250	2500	1500	440	198	1765	1900	20000

Above list only shows an extract of gearboxes available. Additional sizes and variations are available on request.
1) Gearbox standard design (dry). Dimensions and weights not strictly binding. Subject to changes.

Direction of rotation DLG

Seen from propeller onto engine flywheel in direction of travel ahead

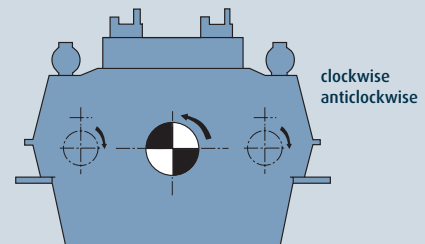
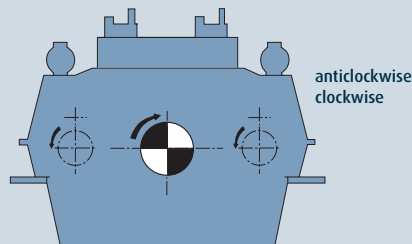



DLG 4431 - 110131

Twin input/single output
reduction gearbox with
hydraulically operated
clutches
Horizontally offset

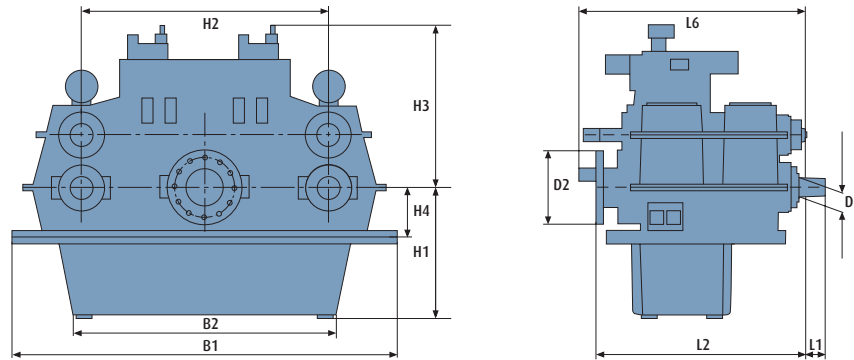

Gearbox DLG	Main Dimensions (mm)											
	B1	B2	D1	D2	H1	H2	H3	H4	L1	L2	L6	Weight kg ¹⁾
4431	3200	2700	187	710	1260	2500	1750	450	237	1920	2210	24000
4447	3900	2800	187	820	1300	2500	1730	500	237	2090	2300	26000
5520	3580	2800	197	650	1250	2500	1800	500	251	1870	2115	28000
5539	3460	2100	197	705	1315	2800	1700	640	251	1995	2115	31000
5547	3580	2800	197	800	1250	2500	1800	640	251	2030	2400	28000
5573	4180	3300	197	860	1410	2800	2050	800	251	2300	2400	32000
6673	4250	2900	217	860	1400	2800	1850	675	263	2540	2350	37000
7747	4300	3300	217	737	1250	2800	1770	550	306	2255	2560	31000
7773	4300	3200	217	750	1250	2800	1800	550	306	2255	2560	31500
8890	4100	3250	247	900	1425	2800	1750	500	321	2370	2700	42000
9990	5220	3000	247	900	1550	3400	2050	750	321	2800	3000	51000
110131	5450	3000	315	950	1550	3400	2050	750	405	2435	3600	61000

Above list only shows an extract of gearboxes available. Additional sizes and variations are available on request.

1) Gearbox standard design (dry). Dimensions and weights not strictly binding. Subject to changes.

DLG series

Twin input/single
output reduction
gearbox for propulsion
with controllable
pitch propeller

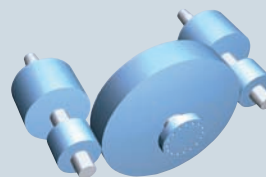
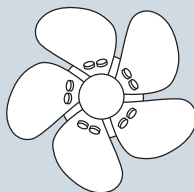

Counter rotation of
input and output

Standards DLG 1113 - 110131

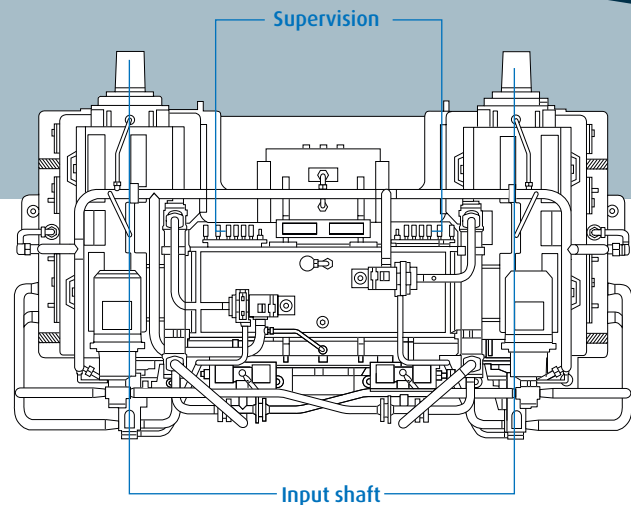
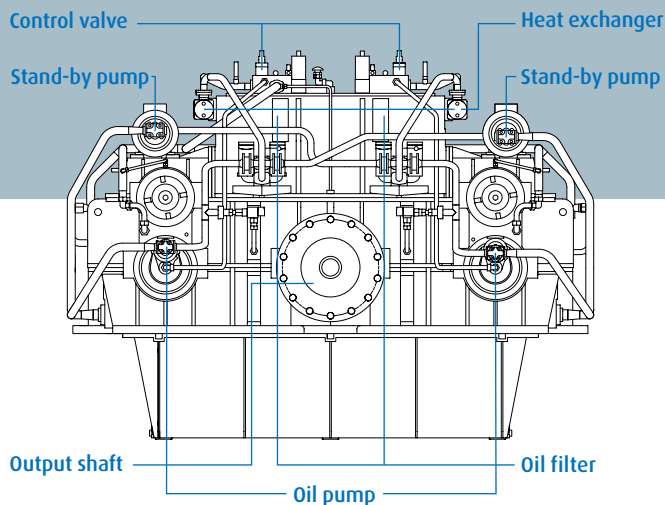

Basic Equipment

- Housing made from grey cast iron or steel housing in torsion stiff design, rigid mounting
- Spur wheels helically toothed and tooth flank ground
- Built-in hydraulically operated disc clutches with steel/sinter friction surface
- Smooth engagement by adapted pressure increase during shifting
- Gearbox either completely equipped with anti-friction bearings, included thrust bearing or for higher ratings output shaft with slide bearings included Mitchell type thrust bearings

Scope of Supply

Standards

- Integrated oil sump. Common circuit for operating pressure and lube oil. Oil pump and oil filter accessible from the outside
- Fitted heat exchanger for cooling water inlet temperature of max. 38°C, seawater resistant
- Connection facility for remote supervision of pressure and temperature
- Built-on control valve, electrically or pneumatically operated
- Emergency control: in case of failure of operating pressure mechanical force locking of the disc clutch is possible
- Input: free shaft end with taper 1:30

- Output: forged-on-flange
- Supervision
 1. Pressure switch – operating pressure too low
 2. Pressure switch – clutch engaged
 3. Temperature sensor (2xPT100) – oil temperature behind heat exchanger
 4. Filter contamination – electrical signal for “filter contaminated”
 5. Thermometer – oil temperature behind heat exchanger
 6. Pressure gauge for operating oil pressure
 7. Temperature supervision for all slide bearings
- Paint coating with synthetic resin varnish. Colour: RAL 7023 concrete grey

Extras

- Output counter flange
- Output shaft with cylindrical shaft end
- Flexible coupling
- Supervision instruments
- Special PTO executions
- Spare part kit as per classification rules
- Paint coating with synthetic resin varnish in all RAL-colours
- Heat exchanger for cooling water temperature higher than 38°C
- Special reduction ratios
- Connection facility for electrical stand-by or trailing pumps
- Built-in propeller shaft brake, hydraulically operated

Subject to changes



O P T I O N S A N D F E A T U R E S



Options

POWER TAKE OFF (PTO) POWER TAKE IN (PTI)

If required, the gearboxes can be fitted with additional Power Take Off (PTO; application: Hydraulic pumps and generators) and Power Take In (PTI).

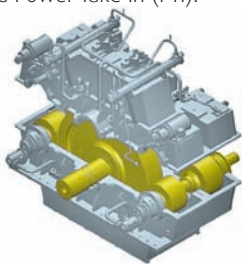

CONDITION MONITORING

Monitoring for all key data for proactive maintenance and management.

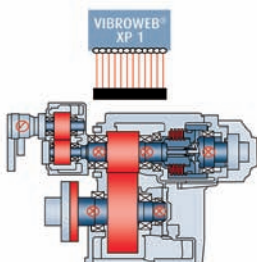

SHAFT BRAKE

The gearboxes can be fitted with a hydraulically operated multiple disk brake built in serving as fixing/stopping brake on twin-screw vessels.

OD-BOX

For all customary CPP systems, the output shaft can be provided with a central bore and a connection for the oil distributor box.



IGS (INTELLIGENT GEARBOX SYSTEM)

Controlled pressure build-up for optimized gear shiftings and minimized drop in engine speed. Thermal monitoring of the clutch for optimized utilization of the thermal limiting value. Preset "back-up"-system to avoid any inadmissibly high drops in engine speed during manoeuvring in "back-up"-mode. Accumulator for mechanical gear shifting in case of voltage failure.

UNATTENDED MACHINERY SPACE

All gearboxes can be supplied with additional supervision instruments, according to classification society rules, enabling the operator to take all necessary information from the bridge.

Duty Cycle Classification

CONTINUOUS DUTY



- Continuous operation with little or no variations in engine speed and power
- Average engine operating hours: unlimited
- Allowable hull forms: semi-displacement, displacement
- Allowable applications: commercial vessels



REINTJES

REINTJES GmbH
Eugen-Reintjes-Straße 7
D-31785 Hameln
Phone + 49 51 51/104-0
Fax + 49 51 51/104-300
www.reintjes-gears.de