

Applications for:

**Fast Vessels WVS/WLS**

Engine Rating up to 1,400 kW

**Fast Ferries VLJ**

Engine Rating up to 13,200 kW

**Work Boats WAF/LAF**

Engine Rating up to 1,200 kW

**Work Boats WAF/LAF**

Engine Rating up to 3,650 kW

**Work Boats WAF/LAF**

Engine Rating up to 8,500 kW

# Fast Vessels 900 - 5,000 kW

## WVS/WLS 730/1-2240

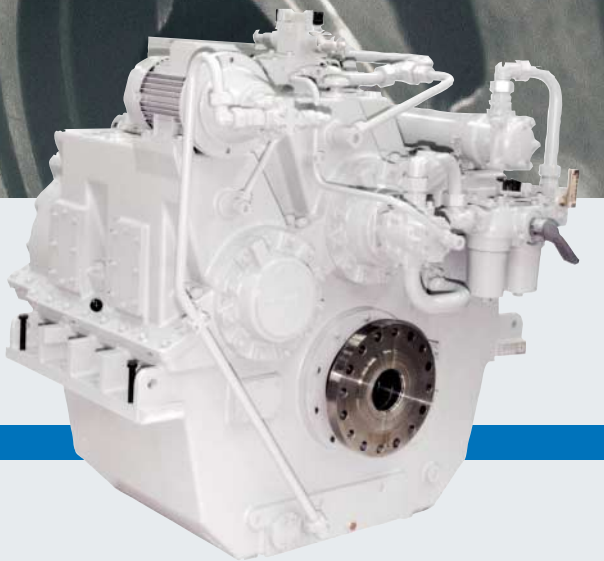

**Work Boats VA**

Engine Rating up to 6,000 kW

**Work Boats DLG/DLGF**

Engine Rating up to 15,000 kW

**Work Boats SVA<sup>1</sup>/SVAL<sup>2</sup>**

Engine Rating<sup>1</sup> up to 20,000 kW

Engine Rating<sup>2</sup> up to 13,000 kW

Y O U R P A R T N E R F O R T H E F U T U R E



# Applications for Fast Vessels

## WVS/WLS 730/1 - 2240



Reverse-reduction gearbox with bell-housing, resilient mounting, vertically offset

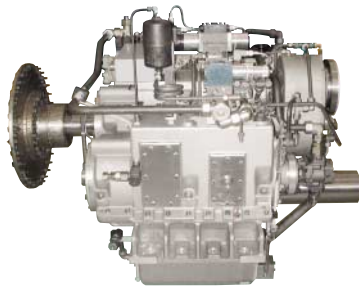

Reduction gearbox with special supervision and PTO incl. SAE pads, vertically offset



Reverse-reduction gearbox with resilient mounting and PTO incl. SAE-Pads, vertically offset



Reverse-reduction gearbox with special supervision and PTO incl. SAE pads, U-drive, vertically offset

### Advantages

WVS- and WLS-gearboxes have been specially designed for fast vessels such as naval units, patrol boats, yachts and other vessels with similarly high performance demands.

We have the backing of over 75 years of experience in marine gearbox production and use

state-of-the-art computation tools and production technologies.

Owing to their design for specific areas of deployment, the hydraulically operated reverse-reduction gearboxes of the WVS series, as well as the reduction gearboxes of the WLS series offer various special advantages:

- High power-to-weight ratio
- Low performance weight due to weight-optimised design
- Finely tuned shifting
- Compact dimensions
- Low operating noise

### Gearbox Selection

The selection diagram opposite gives an overview of the performance ratings of the basic WVS types. These also apply for WVS U, WLS and WLS U units.

However, for the final selection of gearboxes only the ratings of the applicable gearbox selection table are binding.

DESIGNED FOR MEDIUM, LIGHT AND PLEASURE DUTY APPLICATIONS



kW	1000	1200	1400	1600	1800	2000	2200	2400	2600	2800	3000	3200	3400	3600	3800	4000	4200	4400	4600	4800	5000
BHP	1340	1680	1876	2144	2412	2680	2948	3216	3484	3752	4020	4288	4556	4824	5092	5360	5628	5896	6164	6432	6700

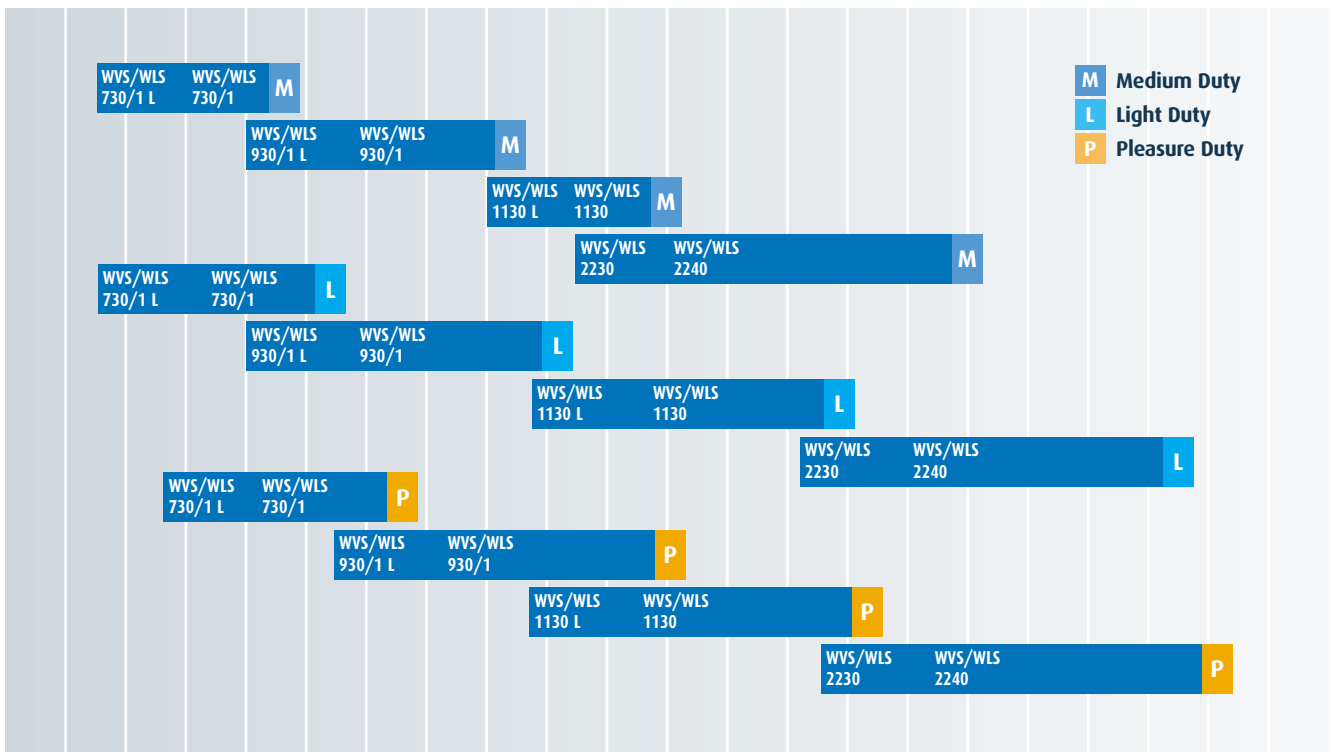

# Marine gearboxes

## WVS/WLS 730/1 - 2240

### WVS/WLS 730/1 - 2240

Reverse-reduction gearboxes with hydraulically operated clutches. Vertically offset. Input and output on opposite sides.

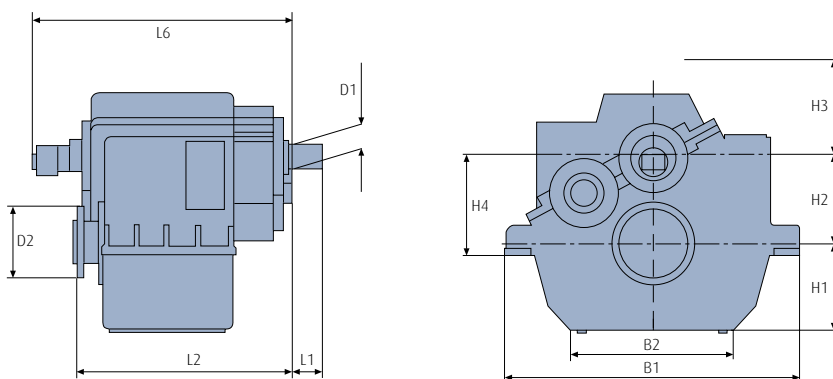

Gearbox	Main dimensions (mm)											Weight kg <sup>1)</sup>		
	WVS/WLS	B1	B2	D1	D2	H1	H2	H3	H4	L1	L2	L6	WVS	WLS <sup>2)</sup>
730/1 L	1036	650	92	260	323	310	540	340	110	795	965	720	570	660
730/1	1036	650	92	260	323	310	540	340	110	795	965	725	575	665
930/1 L	1166	750	102	280	348	340	560	385	120	845	1024	925	725	845
930/1	1166	750	102	280	348	340	560	385	120	845	1024	950	750	870
1130 L	1350	700	117	350	435	425	650	440	157	1085	1255	1550	1270	1410
1130	1350	700	117	350	435	425	650	440	157	1085	1255	1600	1320	1460
2230	1500	700	127	350	500	460	550	475	162	1180	1480	2150	1750	1920
2240	1500	700	127	390	500	460	550	475	162	1180	1480	2185	1830	2000

<sup>1)</sup> Gearbox standard design (dry). Dimensions and weights not strictly binding. Subject to changes. <sup>2)</sup> Counter rotation <sup>3)</sup> Identical rotation

### WVS series

Free-standing  
Close-coupled  
U-drive

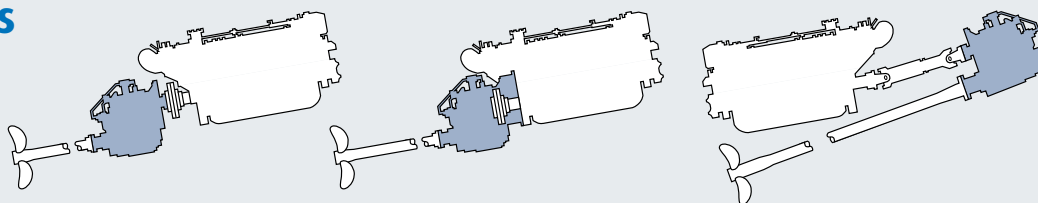

### Direction of rotation WVS/WLS

Seen from propeller  
onto engine flywheel

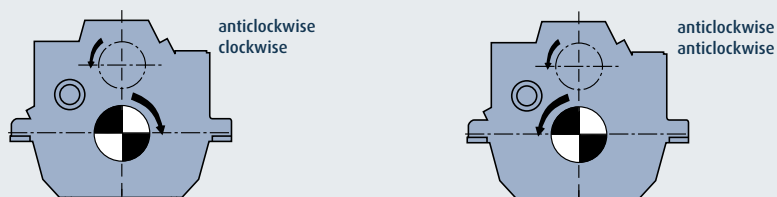



## WVS/WLS 730/1 U - 2240 U

Reverse-reduction gearboxes with hydraulically operated clutches. Vertically offset. Input and output on the same side.

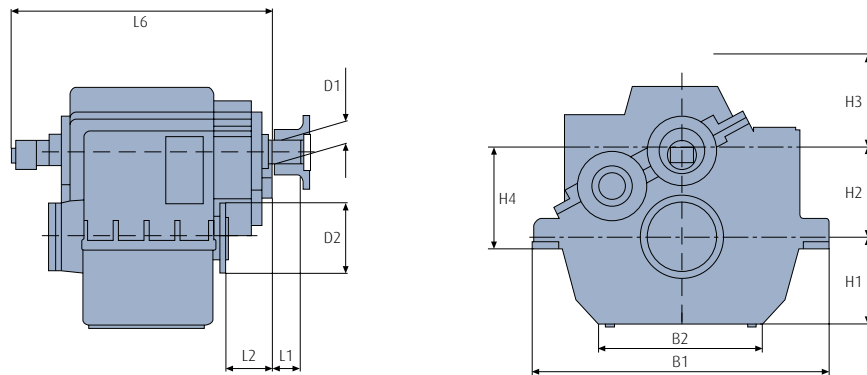

Gearbox	Main dimensions (mm)											Weight kg <sup>1)</sup>		
	WVS/WLS	B1	B2	D1	D2	H1	H2	H3	H4	L1	L2	L6	WVS	WLS <sup>2)</sup>
730/1LU	1036	650	92	260	323	310	540	340	110	145	965	790	600	690
730/1U	1036	650	92	260	323	310	540	340	110	145	965	755	605	695
930/1LU	1166	750	102	280	348	340	560	385	120	175	1024	955	755	875
930/1U	1166	750	102	280	348	340	560	385	120	175	1024	980	780	900
1130 LU	1350	700	117	350	435	425	650	440	157	245	1255	1675	1485	1345
1130 U	1350	700	117	350	435	425	650	440	157	245	1255	1675	1485	1345
2230 U	1500	700	127	350	500	460	620	475	162	230	1480	2175	1950	1780
2240 U	1500	700	127	390	500	460	620	475	162	230	1480	2210	2030	1860

<sup>1)</sup> Gearbox standard design (dry). Dimensions and weights not strictly binding. Subject to changes. <sup>2)</sup> Counter rotation <sup>3)</sup> Identical rotation

### WVS series

Reverse-reduction gearbox for propulsion with fixed pitch propeller

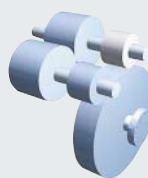
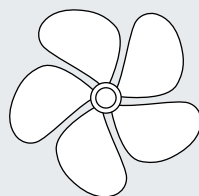

Input and output on opposite sides.

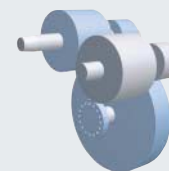

Input and output on the same side.

### WLS series

Reduction gearbox for propulsion with control-lable pitch propeller

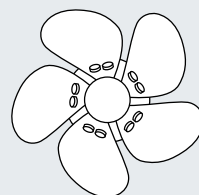

Input and output on opposite sides.

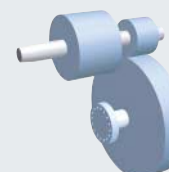

Input and output on the same side.

# Standards WVS/WLS 730/1 - 2240

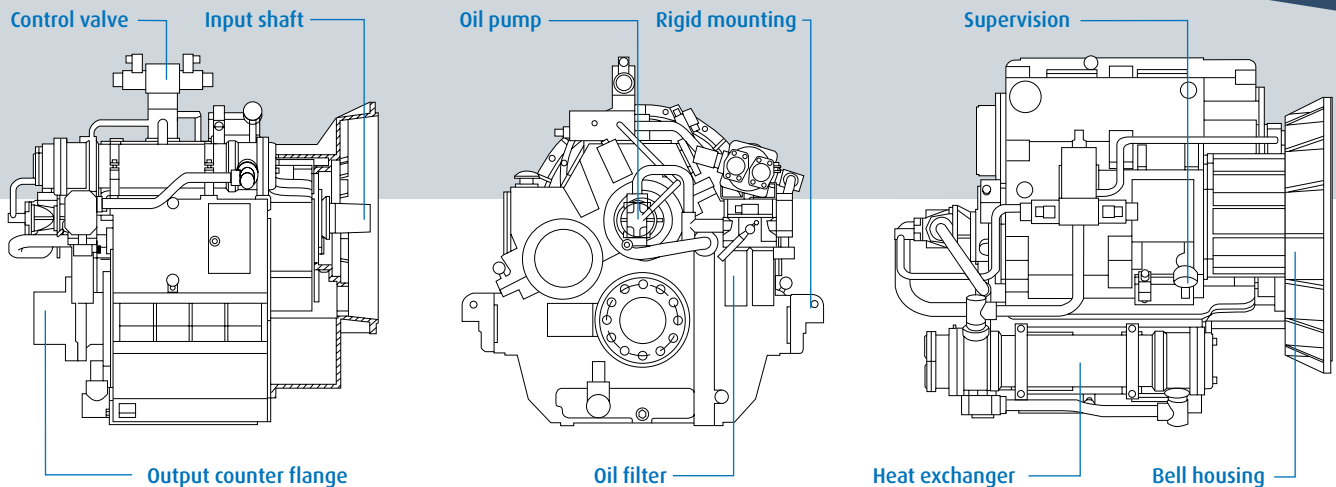

## Basic Equipment

- Housing made from aluminium alloy
- Prepared for mounting of SAE-bell housings
- Spur wheels helically toothed, case hardened and tooth flank ground
- Built-in hydraulically operated disc clutches with steel/sinter friction surface
- Smooth engagement by adapted pressure increase during shifting
- Full power transmission and same reduction in both output senses of rotation

## Scope of Supply

### STANDARD

- Integrated oil sump. Common circuit for operating pressure and lube oil. Oil pump and oil filter accessible from the outside
- Fitted heat exchanger for cooling water inlet temperature of max. 32 °C, seawater resistant

- Fitted pressure gauge for operating pressure as well as connection facility for remote supervision of pressure and temperature
- Built-on control valve, electrically operated
- Input: free shaft end with taper 1:30 (WVS and WLS). Input flange (WVS/U and WLS/U)
- Output: forged-on-flange
- Paint coating with synthetic resin varnish. Colour: RAL 7001 silver grey
- Trolling Valve (ADS)
- PTO
- Resilient mounting
- Special reduction ratios

Subject to changes

## ADS (ACTIVE SPEED CONTROL SYSTEM) CLOSED LOOP OR CONTROLLED

The ADS is used for travelling at low propeller speeds. Speed is varied via the oil pressure in the clutch. The ADS can be engaged in both AHEAD or ASTERN propulsion modes. Reversals with operative ADS are also possible at low ship speeds.

## WVS/WLS SERIES

WVS/WLS gearboxes are also available with partly offset configuration.

### EXTRAS

- SAE bell housing
- Output counter flange
- Flexible coupling
- Supervision instruments
- Spare parts kit as per classification rules
- Paint coating with synthetic resin varnish in all RAL-colours

## Options

### POWER TAKE OFF/IN

If required, the gearboxes can be fitted with additional Power Take Off (PTO) (application: hydraulic pumps) and Power Take In (PTI).

### TWO-SPEED GEARBOXES

Two selectable gear ratios are provided between input and output shaft. This ensures optimal operation of the ship.

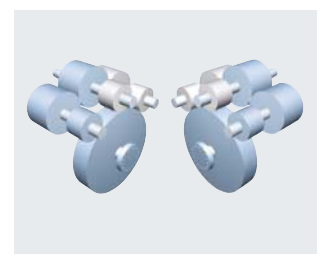
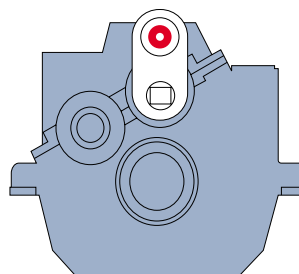



# O P T I O N S   A N D   F E A T U R E S



## UNATTENDED MACHINERY SPACE

All gearboxes can be supplied with additional supervision instruments, according to classification society rules, enabling the operator to take all necessary information from the bridge.



## CONDITION MONITORING

Monitoring for all key data for proactive maintenance and management available.

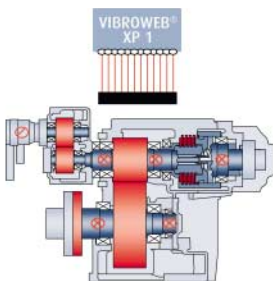

## Duty Cycle Classification

### MEDIUM DUTY

- M** ■ Intermittent operation with some variations in engine speed and power
- Average engine operating hours limit: 4,000 hours/year
- Allowable hull forms: planing, semi-planing, catamaran
- Allowable applications: private, charter and commercial craft, navy and police activity (example: crew boats, high speed ferries)

### LIGHT DUTY

- L** ■ Intermittent operation with large variations in engine speed and power
- Average engine operating hours limit: 2,500 hours/year
- Allowable hull forms: planing, semi-planing, displacement
- Allowable applications: private, charter, sport/leisure activities, naval and police activities

### PLEASURE DUTY

- P** ■ Intermittent operation with very large variations in engine speed and power
- Average engine operating hours limit: 500 hours/year
- Allowable hull forms: planing, semi-planing
- Allowable applications: private, non-commercial, non-charter, sport/leisure activities



REINTJES GmbH  
Eugen-Reintjes-Straße 7  
D-31785 Hameln  
Telefon + 49 51 51/104-0  
Fax + 49 51 51/104-300  
[www.reintjes-gears.de](http://www.reintjes-gears.de)